**CITY COLLEGE OF SAN FRANCISCO
ALEMANY CAMPUS – A.D.A. UPGRADES AND BARRIER REMOVAL
PROJECT – Phase II**

ADDENDUM NO. 1

PROJECT: Alemany Campus – A.D.A. Upgrades and Barrier Removal Project – Phase II
750 Eddy, San Francisco, CA 94109 **DATE:** November 4, 2009

OWNER: City College of San Francisco
50 Phelan Avenue
San Francisco, CA 94112

Notice is hereby given to all prospective bidders that plans and specifications on the subject project are modified as hereinafter set forth. This Addendum shall be attached to and form a part of the plans and specifications. All bidders must acknowledge receipt of this addendum on the Bid Form. In case of difference with previous addenda or communications, this addendum takes precedence.

It is the responsibility of all bidders to notify all subcontractors from whom they request bids and from whom they accept bids of all changes contained in this addendum.

PROJECT MANUAL

1. Item No. PM-1

Reference: Alemany – Class Schedule

Description: Contractor shall not disrupt classes shown in the attached "Alemany Class Schedule." Insert following Section M.

2. Item No. PM-2

Reference – Alemany – Plumbing Specifications

Description – Specification Sections # 15400, 15800. Add in their Entirety.

DRAWINGS

1. Item No. AD1-1

Reference: T1 Title Sheets

Description: Add Plumbing and Mechanical Drawings to the Drawing Index following the Architectural Drawings as follows:

- M01. Mechanical Legend
- M0.2 Mechanical Schedule
- M2.2 Mechanical Second Floor Plan
- M3.1 Mechanical Details
- M3.2 Mechanical Control Diagrams
- P0.1 Plumbing Legend & Detail
- P0.2 Plumbing Schedule
- P2.1 Plumbing First Floor Plan
- P2.2 Plumbing Second Floor Plan

2. Item No. AD1-2

Reference: Mechanical & Plumbing Drawings

Description: Add the following sheets in their entirety to the contract drawings per the Drawing index as noted above:

M01. Mechanical Legend
M0.2 Mechanical Schedule
M2.2 Mechanical Second Floor Plan
M3.1 Mechanical Details
M3.2 Mechanical Control Diagrams
P0.1 Plumbing Legend & Detail
P0.2 Plumbing Schedule
P2.1 Plumbing First Floor Plan
P2.2 Plumbing Second Floor Plan

3. Item No. AD1-3

Reference: Toilet Fixture

Description: Change Keynote 1, sheet A6.1 from "PROVIDE AND INSTALL (N) WALL-MOUNTED TOILET (AMERICAN STANDARD AFWALL 2257.103), CURB-MOUNTED CARRIER & 6" CONCRETE CURB" to **PROVIDE AND INSTALL (N) FLOOR MOUNTED TOILET (ZURN Z5655)**

4. Item No. AD1-4

Reference: Soffit at Admissions and Enrollment Office, First Floor

Description: To conceal (N) waste pipe in the Admissions and Enrollment Office, First Floor, Provide and Install a (N) 1' x1' x 14' (VIF) soffit at south wall. Frame at 16" OC w/ 2x4 wood studs and 5/8" Type X gypboard, Level 4 finish, and paint to match (E).

5. Item No. AD1-5

Reference:

Description: Provide and Install electrical for the following: exhaust fan motor starter, fusible link at fire/smoke damper, lighting, switching and fire alarm at (N) toilet rooms. Provide and Install all associate conduit, cable, and equipment back to nearest panel (assume 50 feet distance) . See Architectural and Mechanical drawings for layouts.

6. Item No. AD1-6

Reference: Roof Patching

Description: At (N) roof exhaust fans, patch and repair roofing to match (E). See Mechanical Drawings for Layout.

END OF ADDENDUM ITEMS

ATTACHMENTS:

Drawings:

M01. Mechanical Legend	1 Page 8-1/2"x14"
M0.2 Mechanical Schedule	1 Page 8-1/2"x14"
M2.2 Mechanical Second Floor Plan	1 Page 8-1/2"x14"
M3.1 Mechanical Details	1 Page 8-1/2"x14"
M3.2 Mechanical Control Diagrams	1 Page 8-1/2"x14"
P0.1 Plumbing Legend & Detail	1 Page 8-1/2"x14"
P0.2 Plumbing Schedule	1 Page 8-1/2"x14"
P2.1 Plumbing First Floor Plan	1 Page 8-1/2"x14"
P2.2 Plumbing Second Floor Plan	1 Page 8-1/2"x14"

Documents:

5 pages	Class Schedule
8 pages	Specifications Sections 15400
14 pages	Specifications Sections 15800

SECTION 15400

PLUMBING SYSTEMS

PART 1 - GENERAL

1.01 GENERAL CONDITIONS

- A. The General Conditions, Supplementary Conditions, and Division 1 General Requirements apply to the work specified in this Section.

1.02 SUMMARY

- A. All materials and operations for a complete and operating plumbing and drainage system, including, but not necessarily limited to, the following:
 1. Soil, waste, and vent piping inside the building including connections to existing piping.
 2. Cold water piping systems inside the building including connections to existing piping.
 3. Plumbing fixtures and trim, including required backing.

1.03 GENERAL REQUIREMENTS

- A. Submittals: A complete list of materials and equipment proposed, accompanied by manufacturer's data sheets, giving sized, capacities, etc., shall be submitted to the architect in quintuplicate. The list shall include specified and/or substituted materials. No consideration will be given to partial or incomplete lists.
- B. Examination of Site: Examine site prior to bidding. Compare it with drawings and specifications. Check conditions and take measurements which may affect work. No allowance shall subsequently be made for any extra expense due to failure to make such examination.
- C. Drawings: Plumbing drawings indicate general arrangement of piping and equipment. Should it be necessary to deviate from arrangement or location indicated in order to meet architectural conditions or site conditions, or due to interference with work in other divisions, such deviations as offsets, rises, or drops in piping that may be necessary, whether shown or not, shall be made without extra expense to owner.
- D. Manufacturer's Directions: Follow manufacturer's directions covering points not shown on the drawings or specified herein. Manufacturer's directions do not take precedence over drawings and specifications. Where these are in conflict with drawings and specifications, notify architect for clarifications before installing the work.
- E. Codes: Work and materials shall be in full accordance with all applicable local or state ordinances, California Building Code, California Plumbing Code, National Fire Protection Association, State of California Safety Orders, and State Fire Marshal. Whenever drawings and specifications require larger sizes or higher standards than are required by regulations, drawings and specifications govern. Whenever drawings or specifications require

something which will violate regulations, regulations govern. No extra charge will be paid for furnishing items required by regulations but not specified or shown on drawings.

- F. Cooperation With Other Trades: Schedule work and cooperate with other divisions to avoid delays, interferences and unnecessary work, conforming to construction schedule, making installation when and where required. If installed work is later found to interfere with work of other divisions, make all necessary changes at contractor's expense.
- G. Licenses, Permits, Services, and Fees: Secure and pay for all permits, licenses, and inspections required to begin, perform and complete work.
- H. Quietness of Operations: Adjust, repair, or replace any equipment producing objectionable noise or vibration in any occupied areas of building, including providing additional brackets, bracing, etc., to prevent objectionable noise or vibrations.
- I. Operating and Maintenance Instructions: Immediately upon completion of work and before final inspection turn over to owner two sets of shop drawings, instruction sheets, bulletins and pertinent information required by owner for proper operation and adjustment of each and every piece of equipment furnished. This information shall be bound in a hard-covered loose-leaf binder, typed, and indexed into sections, and labeled for easy reference.
- J. Manufacturer's Names and Model Numbers: Are used to establish standard of quality. Use only such items or their approved equal. Architect's approval required for all equipment.
- K. As-Built Drawings: submit, within thirty (30) days after date of acceptance, one (1) complete set of sepia reproducible tracings, obtained from the architect, marked to show the installed plumbing and piping conditions, and show all deviations from contract drawings.
- L. Guarantee: Furnish written guarantee that work has been performed in accordance with plans and specifications and to replace or repair to satisfaction of owner, any portion of new work that fails within a period of one (1) year after final acceptance, provided that such failure is due to defects in material or workmanship.

PART 2 - PRODUCTS

2.01 MATERIALS

- A. Soil, Waste and Vent Piping:
 - 1. Above Grade: No-hub cast iron soil pipe and fittings. All pipe and fittings shall conform to CISPI 301, ASTM 888 or ASTM A-74 standards. Pipe and fittings shall be marked with the collective trademark of the Cast Iron Soil Pipe Institute. Pipe and fittings are to be manufactured by AB&I Foundry, Charlotte Pipe, Tyler Pipe or equal. Joints shall be made with No-hub couplings with neoprene gasket, stainless shield and clamp, Tyler pipe, or equal.
 - 2. Below Grade: No-hub cast iron soil pipe and fittings. All pipe and fittings shall conform to CISPI 301, ASTM 888 or ASTM A-74 standards. Pipe and fittings shall be marked with the collective trademark of the Cast Iron Soil Pipe Institute. Pipe and fittings are to be manufactured by AB&I Foundry, Charlotte Pipe, Tyler Pipe or equal. Joints shall be made with No-hub couplings with neoprene gasket. Joints shall be made with heavy duty No-hub couplings with neoprene gasket, stainless shield and clamps. Couplings shall be constructed of type 304 stainless steel with

305 stainless steel worm drive screws. Gaskets per ASTM C564. (4 band 80 inch pound torque). Mission Heavy Weight, Husky SD4000, or equal.

- B. Cold Water Piping:
1. Above grade: Type L copper tubing ANSI H23.1 with wrought copper sweat fittings ANSI B16.22 joined with 95-5 solder.
 2. Below grade: Type L copper tubing ANSI H23.1 with wrought copper sweat fittings ANSI B16.22 joined with 95-5 solder
- C. Unions and Flanges:
1. Steel pipe unions: Malleable iron ground joint pattern with brass to iron seats, 150 psi.
 2. Steel pipe flanges: ANSI B16.C, 15 psi forged steel welding type with flat face.
 3. Copper tubing unions: 150 psi ground joint cast bronze unions with sweat connections.
 4. Copper tubing flanges: ANSI B16.24, bronze, 150 psi to match standard ASA 150 psi steel flanges with flat face.
 5. Flange gaskets: Crane Co Cranite, 1/16" full face sheet packing, 150 psi. Coat gaskets with thread lubricant before installation.
- D. Dielectric Protection:
1. Location: For connection between dissimilar metals in the piping systems to control corrosion caused by galvanic or electrolytic action. No dielectric unions allowed.
 2. Listing: Victaulic Style 47, Lochinvar V-line or equal.
 - a. Dielectric couplings: Threaded for sizes 2 inches and smaller, grooved or flanged for 2-1/2 inches and larger.
- E. Thread Lubricant for Steel Pipe: Armite Joint Seal Compound No. 250.
- F. Valves: Shall be a product of single manufacturer, Red-White or equal.
1. Gate valves (threaded): #280, bronze, 125 psi.
 2. Gate valves (solder): #281, bronze, 125 psi.
 3. Check valves (Threaded): #236, bronze swing check, 125 psi.
 4. Check valves (solder): #237, bronze swing check 125 psi.
 5. Ball valves (threaded): #5544, bronze, 400 psi, full port.
 6. Ball valves (solder): #5549, bronze, 400 psi, full port.
 7. Valves shall be same size as line in which they are installed. No valve shall be installed with stem pointed below horizontal.
- G. Pipe Sleeves: Adjust-To-Crete 24 ga. ,electrogalvanized sheet metal adjustable sleeve, or equal.
- H. Pipe Hangers and Supports: Superstrut or equal.
1. Horizontal piping: C-711 J-Hanger.
 2. Vertical piping: C-720 riser clamp.
 3. Multiple piping runs and piping supported from walls, A-1200 channel and standard fittings and pipe clamps.
 4. Inserts: 452TB or C-475.

5. Beam clamps: US-562, U-569, C-775L or M-778.
 6. Missed placed or missed specified inserts: Phillips Red Head Anchor Sleeves.
 7. Rods: H-104.
- I. Cleanouts: Zurn or equal, as scheduled on drawings. Cleanouts shall be furnished with flashing collars when installed in membraned slabs. Furnish suitable wrought iron or steel wrenches for each style of cleanout plug cap.
- J. Plumbing Fixtures: Make and model as scheduled on the drawings or equal.
1. Fixtures and trim: As described in manufacturer's catalog with modifications noted.
 2. Vitreous ware fixtures: White, twice-fired, vitreous china.
 3. Fixture trim and exposed metal items: Chrome-plated unless otherwise noted. Pipes passing through finished walls shall have chrome-plated escutcheon plates.
 4. Install stops in each water supply to fixtures.
 5. No unoccupied fixture faucet holes shall be permitted.
 6. Fix exposed fixture setting bolts with china caps.
 7. Properly support and securely fasten all fixtures to adequate backing per manufacturer's recommendations.
 8. Point up joints between fixture and wall or floors with white mastic. Mastic shall have sufficient resiliency to prevent cracking or pulling away from wall due to fixture movement.
 9. Rough-in and set fixtures to height shown on architectural drawings or as standard for the industry.
- K. Escutcheon Plates: For pipes passing through finished ceilings, walls, and floors in conspicuous locations, use chromium-plated steel floor and ceiling plates with set screw or other approved means of holding securely in place.
- L. Flashing and Counterflashing: For cast iron pipe penetrations through roof, use 4 pound lead flashing with counterflashing. For copper pipe penetrations through roof, use copper flashing and counterflashing.
- M. Access Panels:
1. In areas other than toilet rooms: Karp Model DSC-214-M, or equal, prime coated steel with 14 gauge door and trim and 16 gauge frame, continuous concealed piano hinge, flush screwdriver operated cam latch, size shall be 12" x 12".
 2. In toilet rooms: Karp Model DSC-214-M, or equal, Type 304 stainless steel, continuous concealed piano hinge, flush screwdriver operated cam latch, size shall be 12" x 12".
- N. Underground, Uninsulated, Steel Pipe Lines: Shall be wrapped conforming to AWWA HOC203.
- O. Piping Identification:
1. Piping identification shall be manufactured by Brady or equal.
 2. Materials:
 - a. Color: Unless specified otherwise, conform with ANSI/ASME A13.1.

- b. Plastic nameplates: Laminated 3-layer plastic with engraved black 2 inch letters on light contrasting background color.
 - c. Metal tags: brass aluminum with stamped letters; tag size minimum 1-1/2 inch diameter with smooth edges.
 - d. Plastic pipe markers: Factory fabricated, flexible, semi-rigid plastic, pre-formed to fit around pipe or pipe covering; minimum information indicating flow direction arrow and fluid being conveyed.
- P. Equipment or products specified on the Drawings: Each equipment or product manufacturer and model specified on the drawings is "or equal."
- 1. Water closets.
 - 2. Lavatories.
 - 3. Floor cleanouts.
 - 4. Wall cleanouts.

PART 3 - EXECUTION

3.01 GENERAL

- A. Support exposed and concealed piping on specified hangers properly spaced and set to allow piping to adjust for temperature change expansion and contraction. Evenly space and support piping in parallel.
- B. Coordinate with other trades to provide continuous support channel for all pipes and conduit in exposed locations.
- C. Conceal piping in ceilings, furred walls, partitions and pipe spaces, except where noted otherwise. Provide maximum headroom and run piping to maintain proper clearance for piping runs beforehand and with other divisions to insure clearance. Where work of other divisions prevents installation of piping shown on drawings, reroute piping as directed by architect at no extra cost to owner.
- D. Install exposed piping parallel to or at right angles with building walls.
- E. No valve, piece of equipment, or trim shall support the weight of any pipe. Install valves, traps, cleanouts, etc., in accessible locations.
- F. Install piping free from traps and air pockets.
- G. Use special wrenches in assembly of polished, chrome-plated tubing and fittings so that no tool marks are left on pipe fittings.
- H. Wherever changes in sizes of piping occur, use reducing fittings.
- I. Install unions adjacent to threaded valves, equipment, and at other points where required for disassembly.
- J. Provide sleeves wherever pipes run through walls, slabs, beams, footings, and floors large enough for passage of pipe and/or pipe insulation. Sufficiently size sleeves to allow for contraction and expansion of pipe. Pack sleeves with approved packing material. Pack sleeves in walls and slabs below grade and through exterior walls above grade with water-proof mastic or grout.

- K. Set floor drains and floor cleanouts so top of plate and rim will be flush with top of finish flooring.
- L. Where sleeves are missed or misplaced during canning, core holes with rotary diamond tooth core drills.
- M. Fit exposed pipes which pass through walls, ceilings, or floors in finished rooms and conspicuous locations with escutcheon plates.
- N. Install insulating unions or flanges at ferrous and non-ferrous piping connections.
- O. Install 12" long air chamber on hot and cold water supplies on all non-single handle faucets such as mop sinks and on cold water supplies to hose bibbs.
- P. Install water hammer arrestors at all locations of fast closing positive shut-off valves and equipment with fast closing or solenoid valves; including but not limited to flush valves, single handle faucets, dishwashers, etc. Install behind wall access panel with ball shut-off valve. Follow manufacturer's installation instructions for proximity to valve and specific configuration of inlet piping.
- Q. Minimum bury for exterior piping: 30" below finish grade, except as otherwise noted or determined by invert elevations.
- R. Polyethylene piping system to be installed in strict accordance with the pipe manufacturer's installation requirements.

3.02 PIPE HANGERS, SUPPORTS, AND BRACES

- A. General: Support piping from building structure so that there is no apparent deflection in piping runs. Fit piping with steel sway braces and anchors to prevent vibration and/or horizontal displacement under load when required. Support piping only by approved pipe hangers. Pipes shall not be supported from, or braced to, ducts, other pipes, conduits, or any materials except building structure. Piping or equipment shall not be supported or hung by wire, rope, plumbers tape or blocking of any kind.
- B. Hanger spacing (not for piping or multiple piping supports):

<u>Type of Pipe</u>		
Steel pipe	10'-0" 3/4" diam. & smaller	12'-0" 1" diam. & larger
Copper Tubing	6'-0" 1-1/2" diam. & smaller	8'-0" 2" diam. & larger
Cast iron pipe	All sized 5'-0" max. and not less than one hanger per joint.	
- C. Multiple piping support: 6'-0".
- D. Support vertical piping at each floor level with riser clamps.
- E. Piping at completion of job shall be rigid and immobile. Install additional pipe supports, brackets, and hangers as required to accomplish a rigid and immobile piping system.
- F. Double wrap copper pipe with heavy vinyl tape where pipe comes in contact with ferrous materials.

3.03 EXCAVATING, TRENCHING, AND BACKFILLING

- A. Trenches: Shall have uniform grades. In case of over-excavation, fill to bottom of pipe with selected fill or sand. Provide dewatering pumping as required.
- B. Shoring: Comply with earthwork section of specifications.
- C. Cleaning of Trenches: After pipe lines have been tested, inspected, and approved, and prior to backfilling, remove forms, trash, and debris from trenches then backfill.
- D. Backfill and Compaction: Comply with earthwork section of specifications.

3.04 CLEANING

- A. Thoroughly clean exterior and interior of piping, equipment, and materials before systems are put in operation. Clean plumbing fixtures with soap and water. Remove marks and labels. Clean and polish chrome. Remove paint, concrete, plaster, and other foreign materials. Clean valve handles and stems of any paint, dirt, or other foreign materials. Clean drains of dirt and debris. Remove shipping paper from cleanout covers and drain strainers and polish. Remove and clean out dirt and debris from pipe spaces, including wire and blocking.

3.05 ADJUSTMENTS

- A. Adjust water closet flush and urinal valves to provide proper flush. Adjust faucets to their normal working conditions. Adjust water heaters to 120°F. Adjust gas pressure regulator to specified settings.

3.06 TESTING

- A. Soil Waste and Vent Piping:
 - 1. Test with minimum height of stand pipe 10'-0". Test duration of minimum of four (4) hours.
- B. Cold Water Piping:
 - 1. Hydrostatically test under a pressure of 150 psi at highest point for minimum test duration of four (4) hours.
- C. If systems are tested in sections, include connection to previously tested section. Final pressures at end of test period shall be no more nor less than that caused by expansion or contraction of test medium due to temperature changes. Apply tests for a minimum period of four (4) hours or as required by local codes. Where testing pressures are higher than rated pressure for equipment, or special trim, remove and bypass item with temporary piping for purposes of test.

3.07 PIPING IDENTIFICATION

- A. Installation:
 - 1. Degrease and clean surfaces to receive adhesive for identification materials.
 - 2. Plastic nameplates: Install with corrosive-resistant mechanical fasteners or adhesive.
 - 3. Plastic or metal tags: Install with corrosive-resistant chain.

4. Plastic pipe markers: Install in accordance with manufacturer's instructions.
5. Valves: Identify valves in main and branch piping with tags.
6. Piping: Identify piping, concealed or exposed, with plastic pipe markers. Tags may be used on small diameter piping. Identify service, flow direction, and pressure. Install in clear view and align with axis of piping. Location of identification not to exceed 20 feet on straight runs including risers and drops, adjacent to each valve and "T", at each side of penetration of structure or enclosure, and at each obstruction.
7. Provide valve chart and schedule in aluminum frame with clear plastic shield. Install at location as directed.

3.08 STERILIZATION OF WATER MAINS

- A. At the completion of all work and after the system is tested, flushed, and cleaned, all potable water lines shall be sterilized in accordance with local Department of Public Health, "AWWA" Standard C601, and the following:
 - B. Water treatment firm shall be Bennett Marine Utility, Inc., Burlingame, California, or approved equal.
 - C. A solution of sodium hypochlorite containing not less than 200 ppm of free chlorine shall be injected into the system in such a manner as to insure that the entire system is completely filled with the solution. During this procedure, all valves shall be operated and outlets shall be tested for residual chlorine. Injection shall continue until all outlets indicate at least 200 ppm of free chlorine.
 - D. After injection, the system shall be isolated and the solution held in retention for a period of not less than three (3) hours. Tests shall be made for residual chlorine for retention. If such tests indicate less than 200 ppm of residual chlorine, the entire procedure shall be repeated. After satisfactory sterilization has been effected, the system shall be flushed from an approved source, until all traces of chlorine have been removed or until the chlorine content is no greater than that in the existing supply.
 - E. A Certificate of Sterilization/Chlorination, together with bacteriological reports, shall be prepared by the water treatment firm and delivered to the architect and mechanical engineer stating the work has been done in accordance with the specifications set forth above and prior to final acceptance by owner.

END OF SECTION

SECTION 15800

VENTILATING SYSTEMS

PART 1 – GENERAL

1.01 GENERAL CONDITIONS

- A. The General Conditions, Supplementary Conditions, and Division 1 General Requirements apply to the work specified in this section.

1.02 SUMMARY

- A. The work shall consist of furnishing all labor, materials, and equipment required to complete the installation of the ventilating systems as indicated on the drawings and described herein, including all incidental work necessary to make it complete and satisfactory and ready for operation. Work shall include but not be limited to the following principal items:
 - 1. Exhaust fan.
 - 2. Air distribution equipment including grilles.
 - 3. Complete control system.
 - 4. Duct systems, complete with necessary volume dampers, access doors, hangers, supports, and accessories for the following service:
 - a. Exhaust air systems.
 - 5. Fire/smoke damper.
 - 6. Access panels and doors in ductwork and sheet metal plenums.
 - 7. Access panels in ceiling and drywall enclosures which relate to this trade and coordination for the proper location of the panels.
 - 8. Testing and adjusting all system components.
 - 9. Testing and balancing of all air systems.

1.03 RELATED WORK

- A. Electrical Systems, Division 16.
- B. Grounds or backing for grilles, diffusers, and registers.
- C. Cutting, patching and painting of architectural and structural items.
- D. Installation of ceiling and drywall enclosure access panels.

1.04 GENERAL REQUIREMENTS

- A. Verification of Conditions: Prior to installation of air conditioning work, contractor shall inspect all surfaces to receive said work and arrange with the general contractor for the satisfactory correction of all defects in workmanship and/or material that could interfere with the work specified herein. Installation of any air conditioning work or materials on any surface shall constitute acceptance by the contractor of such surfaces as being in proper condition to receive herein specified materials.

- B. Compliance with Codes: All work must comply with requirements of all applicable codes, laws, ordinances, and regulations of all authorities having jurisdiction.
- C. Permits, Plan Check, Licenses, and Inspections: Shall be obtained and paid for by this contractor. He shall furnish all required plans to obtain such permits. He shall furnish approved certification of all such inspections and permits to the architect.
- D. Examination of Drawings and Existing Conditions: The contractor shall carefully study the mechanical, architectural, structural, and electrical drawings. He shall make himself thoroughly familiar with all requirements. He shall verify existing conditions and compare with the new work required. Any discrepancies shall be brought to the architect's immediate attention. No extra compensation will be allowed for extra work for the contractor's failure to follow this direction.
- E. Substitutions, Material List, Shop Drawings:
1. When specific names are used in connection with materials, they are used as standards only, but this implies no right to use other materials or methods unless approved by the architect.
 2. Decision of the architect shall govern as to what materials are acceptable substitutions. Burden of proof as to equality of any proposed fixtures, material, or equipment shall be upon the contractor. Petition in favor of proposed substitute materials shall be made directly by the contractor. If any tests are necessary to determine quality of proposed items, such tests shall be made at the expense of the contractor by an unbiased laboratory satisfactory to the architect.
 3. Submit shop drawings and material list in six (6) copies. Submit material list and shop drawings after official award of contract. Obtain approval of the architect before installation. Shop drawings shall be submitted for all materials, equipment, and controls.
 4. Check shop drawings and submittals before forwarding to architect and ascertain that submittals meet all requirements of drawings and specifications and conform to structural space conditions.
 5. Shop drawings also shall be prepared for modifications to architectural, plumbing, electrical, and mechanical work required by proposed materials - i.e., relocation of drains, revised electrical circuits, relocation of penetrations, gas pipe sizing changes, etc.
 6. Installation of any approved substituted equipment is the contractor's responsibility and any changes required to work included under other sections for installation of approved substituted equipment must be made to the satisfaction of the architect and without any additional cost. Approval by architect of substituted equipment and/or dimension drawings does not waive these requirements.
 7. Review of drawings and materials submitted for approval shall not be construed as a complete check or constitute a waiver of the requirements of the plans and specifications. This review shall not relieve the contractor of the responsibility to fit the proposed materials to the spaces provided and to effect necessary rearrangement or construction of other work. Contractor agrees that shop drawing submittals processed by the engineer do not become contract documents and are not change orders; that the purpose of the shop drawing review is to establish a reporting procedure and is intended for the contractor's convenience in organizing his work and to permit the engineer to monitor the contractor's progress and understanding of the design. The process of review of the contractor's submittals is not for the purpose of testing the engineer's perception. If deviations, discrepancies, or conflicts between shop drawing submittals and the contract documents are discovered either prior to or

- after the shop drawing submittals are processed by the engineer, the contractor agrees that the contract documents shall control and shall be followed.
8. Submittal lists shall include the identifying marks assigned to the items. Give name of manufacturer, brand name, and catalog number of each item. Submit complete list at one time with items arranged and identified in numerical sequence within each section and article specifications. Listing items "as specified" without both make and model or type designation is not acceptable, except as noted. Only pipe and fittings not specified by brand names may be listed "as specified" without manufacturer's name, provided proposed materials comply with specification requirements. Descriptive Data: Submit six (6) copies of complete description information and performance data covering equipment that is specified but for which catalog plate numbers, brand names, or specific models have not been used. Include fan performance curves.
 9. Submittal of substitutions shall be limited to one proposal for each type or kind of item, unless otherwise permitted by the architect.
- F. Drawings:
1. Layout of the equipment and work is generally diagrammatic, unless specifically dimensioned. Drawings and details shall be checked for interference as governed by structural or other details before installing the work. The right is reserved to make any reasonable change in location of equipment and piping system shown on the drawings without entailing an increase in contract price.
 2. Prepare such shop drawings as may be required for the work under this Section. Refer to "Materials and Substitutions."
 3. All dimensions and locations of mechanical equipment, doors, partitions, etc. are to be taken from the architectural plans but shall be verified at the site.
- G. Materials and Workmanship:
1. All materials and equipment to be new and in perfect condition. Materials or equipment for similar uses are to be of same type and manufacturer.
 2. Workmanship shall be of best standard practice of the trade.
- H. Protection of Equipment: The contractor shall be responsible for damage to any of the work of this section until final acceptance. Cover all openings, apparatus, equipment, and appliances both before and after being set in place to prevent misuse or disfigurement of the apparatus, equipment, or appliances.
- I. Openings:
1. The contractor shall cooperate with other trades in providing information for openings required in walls, floors, and roof for ducts and equipment.
 2. The contractor shall pay all extra costs for cutting of openings as a result of incorrect, delayed, or neglected information.
 3. Make absolutely watertight any openings through waterproofed construction caused by the penetration of ductwork or piping and in a manner approved by the architect.
- J. Clean-up:
1. Thoroughly clean all parts of the apparatus and equipment. Exposed parts which are to be painted shall be thoroughly cleaned of cement, plaster, mastic, and other materials, and all grease and oil spots removed with cleaning solvent.
 2. Inside of all pipes, ducts, etc. shall be flushed or cleaned before being placed in operation, and all strainers shall be cleaned after operational tests.

3. Remove all debris and surplus equipment and leave installation in perfect condition ready for use.
- K. Construction Review:
1. All services rendered by the Architect or any of his consultants consist of professional opinions and recommendations made in accordance with generally accepted engineering practice.
 2. Under no circumstances is it the intent of the Architect or any of his consultants to directly control the physical activities of the contractor or the contractor's workmen in the accomplishment of work on this project.
 3. The presence of the field representative of the Architect or any of his consultants at the site is to provide to the owner and/or architect an additional source of professional advice, opinions, and recommendations based upon the field representative's observations.
- L. Safety:
1. In accordance with generally accepted construction practices, the contractor will be solely and completely responsible for conditions on the jobsite, including safety of all persons and property during performance of the work. This requirement will apply continuously and not be limited to normal working hours.
 2. Construction review by the engineer or any of his consultants is not intended to include review of the adequacy of the contractor's safety measures in, on, or near the construction site or at any other location.
- M. Operating Instructions:
1. Upon completion of the work, the contractor shall place a competent person in charge who will operate the system and instruct the owner's representatives in all details of the operation and maintenance.
 2. The contractor shall carefully prepare four descriptive booklets of the new heating, ventilating, and air conditioning systems and a full description of the operation and maintenance of each piece of equipment.
- N. Guarantee:
1. The contractor shall furnish a written guarantee to the owner that the new materials, equipment, and installation are new, free from mechanical defects, noiseless, and are in perfect operating condition.
 2. He shall guarantee to replace and repair at his own expense any and all unsatisfactory and defective work and items to the satisfaction of the owner for a period of one (1) year after the system is put to beneficial use.
 3. The contractor shall also furnish the owner with all manufacturer's written guarantees of materials and equipment.
 4. See also DIVISION 1.
- O. Record Drawings: See DIVISION 1.

PART 2 - PRODUCTS

2.01 MATERIALS

- A. Access Doors:

1. General: All concealed valves, controls, fire dampers, volume dampers, etc., shall be provided with access doors which shall be furnished under the work of this section and installation shall be the responsibility of the general contractor. Access doors are not required in removable ceilings. Access doors which provide access to fire dampers are to be labeled with one-half inch (1/2") high letters reading "Fire Damper."
 2. Access doors shall be bonderized steel, with flush screwdriver operated cam latch, fitted with concealed hinges, factory prime coated. Doors shall be Milcor, or approved equal, Style "A" for acoustical tile, Style "B" for acoustical plaster, Style "K" for nonacoustical plaster, and Style "M" elsewhere, 24" square unless otherwise noted on the drawings. Access doors in 1 or 2-hour construction shall be Milcor or equal U/L "B" label doors.
- B. Air diffusers, grilles and registers:
1. Provide opposed blade damper volume controls only where specifically shown on the drawings.
 2. Contractor to verify that the mounting frame of ceiling diffusers, grilles, and registers matches the ceiling system actually being installed. Color to be standard off-white.
 3. All air diffusers, grilles, and registers are as shown on the drawings.
 4. Sidewall supply diffusers are to have adjustable, double deflection blades.
 5. Manufacturer: Titus or equal.

2.02 EQUIPMENT

- A. Exhaust Fans:
1. Greenheck series G or equal direct drive, roof-curb mounted, centrifugal roof exhaust fans.
 2. Fans shall have non-overloading, backwardly inclined, centrifugal wheels, birdscreens, direct drive motor, aluminum housing, backdraft damper, and disconnect switch, all completely weatherproofed for outdoor installation.
 3. Provide all options and accessories as scheduled on the drawings.
- B. Fire/smoke dampers:
1. Fire/smoke dampers are to be installed in the duct in each location shown on the drawings.
 2. All fire/smoke dampers and smoke detectors are to be listed by the California State Fire Marshal's office and are to be carefully installed in accordance with the manufacturer's instructions so as to comply with the listing requirements and local codes.
 3. Vertical damper at corridor wall penetrations where duct serves the corridor is to be combination fire/smoke damper. Ruskin Model FSD36 Leakage Class II complete with sleeve, Ruskin Model TS150 Fire Stat with SP 100 (damper blade position) Indicator Switch Package, 120v actuator.
 4. The smoke detector is to be furnished and installed under the fire alarm section of the work. The HVAC system contractor is to coordinate with the fire alarm contractor to ensure each fire/smoke is functioning as required.
 5. Provide access openings with galvanized steel cover plates in the duct adjacent to each fire/smoke damper for servicing.

6. Combination fire/smoke dampers are to be furnished and installed under the Mechanical section of the work. See Divisions 26 and 28 for all wiring including power, fire alarm data loop, and/or indicator switch wiring and for the smoke detector.

2.03 SYSTEMS

A. Duct Systems:

1. Sheet Metal Work - (2500 FPM, +2.0" SP to -2.0" SP): Exhaust air duct systems:
 - a. General: Duct shall be round spiral lock seam or rectangular galvanized steel construction.
 - b. Duct Construction:
 - 1) General: Construction shall be in accordance with the latest ASHRAE Standards, SMACNA 1995 Second Edition HVAC Duct Construction Standards with 1997 Addendum 1, California State Building Code, and the Title 24 energy standards.
 - 2) All duct joints and seams are to be constructed to meet the requirements of the SMACNA 1995 Second Edition Duct Construction Standards with 1997 Addendum 1. Manufactured joints, such as Ductmate or TDC, are to be installed in strict accordance with the manufacturer's installation requirements.
 - 3) Care shall be taken to ensure that all duct reinforcing requirements are met.
 - 4) All 90° branch fittings for round ducts are to be of the conical tee type, conical saddle tap, or as detailed on the Drawings.
 - 5) All spiral duct and fittings inside buildings to be United McGill, Uni-Seal, or approved equal.
 - 6) Spiral duct joints for diameters up to 36" are to be fabricated using sleeve type couplings. Galvanized steel "Uni-Rings" or angle iron rings are to be used for joints on ducts 36" diameter and larger.
 - 7) Commercial gauge adjustable elbows may be used in concealed areas for duct sizes up through 14" diameter. For duct sizes greater than 14" diameter and where duct is exposed, elbows shall be United McGill "Uni-Seal" gored elbows or approved equal.
 - 8) All spiral round duct shall be installed in strict accordance with the manufacturer's requirements.
 - 9) All rectangular duct, fittings and plenums are to be constructed in accordance with SMACNA 1995 Second Edition Duct Construction Standards with 1997 Addendum 1.
 - 10) All roof mounted ducts or ducts exposed to weather are to have flanged and gasketed longitudinal joints; ductmate TDC or TDF.
 - 11) All elbows and bends are to be made with the minimum inside radius equal to 1.5 times the duct diameter or centerline radius (R/W=1.5), where possible. If field conditions do not allow 1.5 inside radius, provide elbow and bend radius as long as possible. Elbow and bend radius shall be no less that that shown on the drawings. All conditions with less than 1.5 inside radius must be approved by the Architect, prior to fabrication and/or installation.
 - c. Ducts are to be sealed so as to conform to SMACNA Duct Seal Class C. Duct tape as a sealant is not acceptable. A brush applied, high pressure duct sealant is to be utilized, MEI or approved equal. Sealant is to be verified that it

is suitable for painting. Duct sealant is to be applied in complete accordance with the manufacturer's application instructions.

2. General:

- a. Access Doors: Doors in sheet metal ducts and plenums for access to dampers, extractors and equipment shall be No. 18 gauge, and made airtight by means of felt strips. Doors shall be sized as required for reasonable service access. Minimum size shall be 12" x 12" unless limited by duct size.
- b. Balancing Dampers: Shall be furnished and installed where required to completely balance and otherwise adjust the air quantities to all supply and return outlet, branch ducts and exhaust grilles. Manual balance dampers shall be provided in each branch duct. Damper to be one gauge heavier than the duct gauge. One damper blade required for ducts to 10" wide, two (2) for ducts 12" to 14" deep. Provide Jiffy Bearings JB-1 damper hardware. Balancing dampers shall not be installed in the collar of any flexible duct. Where shown on the drawings, install remote cable operated dampers, Young regulator model 5020-1200 or equal. Install model 896-FS concealed cap in finished ceiling. Coordinate exact ceiling location of concealed cap in field with architect.
- c. Painting: Paint the inside of all backs of grilles and outlets, extending as far as visible with flat black paint.
- d. Flexible connections for supply and return air ducts at air conditioning units and exhaust fans shall be 16 oz. airtight "Ventglass" non-combustible fabric with fire retardant neoprene coating on outside. Attach to ductwork by lock seam. Install not more than 6" long.

B. Mechanical Identification

1. Materials:

- a. Color: Unless specified otherwise, conform with ANSI/ASME A13.1.
- b. Plastic nameplates: Laminated 3-layer plastic with engraved black 2 inch letters on light contrasting background color.
- c. Metal tags: Brass aluminum with stamped letters; tag size minimum 1-1/2" diameter with smooth edges.

C. Electrical Work:

1. The following electrical work is required to be provided and installed under Division 16.
 - a. Motor starters and disconnect switches for all motors, except where specifically specified, to be furnished by the equipment manufacturer.
 - b. Line voltage wiring and conduit to motors, motor starters, and disconnect switches.
 - c. Line voltage wiring and conduit to switches as indicated on temperature control diagrams.
 - d. Line voltage wiring and conduit for remote control of motors.
2. If contractor furnishes equipment requiring changes in electrical work, it shall be the responsibility of the contractor to arrange and pay for such changes to result in no additional cost to the Owner.
3. Contractor shall be responsible for checking electrical drawings and verifying actual voltage to be supplied before ordering equipment.

4. Contractor shall provide for the complete installation of wiring and controls required for heating, ventilating, and air conditioning equipment, and shall be responsible for the proper operation of the complete system.

D. Seismic Restraint Systems

1. All mechanical system components including, but not limited to, air ducts, piping, air conditioning units, supply fans, and exhaust fans, shall have seismic restraints as required to meet the requirements of Title 24, Chapter 23, of the California State Building Code.
2. Pipes, ducts, and conduits shall be supported and braced per OSHPD anchorage pre-approval No. R-0010, the SMACNA "Guidelines for Seismic Restraints of Mechanical Systems and Plumbing System for pipes and conduits only or No. R-0120, Unistrut "Seismic Bracing Systems", R-0215, the "National Uniform Seismic Installation Guidelines," or other OSHPD pre-approved system. Once the exact location of all pipes and ducts has been established, the structural engineer must check the adequacy of the supporting structure to ensure that the original design is still adequate. See footnotes 14 and 15 to CCR Title 24 Part 2 Table 16A-0 for limitations.
3. The contractor shall submit additional shop drawings, details and calculations for approval by the Architect and the Division of the State Architect (DSA) if such additional drawings and details are required to show actual, alternate, or additional anchorage and bracing required to conform to actual equipment, systems, or material furnished.
4. All fixed equipment is required to be seismically supported, mounted, and restrained. Supports and anchorage details along with substantiating calculations are required for the following:
 - a. Equipment with operating weight over 500 pounds that is mounted directly on the floor or roof.
 - b. Equipment with an operating weight over 20 pounds that is suspended from the roof, floor or wall or that is supported by vibration isolation devices.
5. It shall be the contractor's responsibility to furnish and install all required seismic bracing, supports for all equipment, piping and duct systems required to meet the above-referenced sections of Title 24 of the California Administrative Code. No attempts have been made to identify all of the locations and details of the required supports. The method and details are at the contractor's option, using the guidelines referred to in Paragraph .2 above.

E. Testing, Adjusting and Balancing:

1. Scope includes but is not limited to:
 - a. Testing, adjustment, and balancing of air systems.
 - b. Measurement of final operating condition of Heating and Ventilating systems.
2. References:
 - a. AABC: National standards for field measurement and instrumentation, total system balance.
 - b. ASHRAE Systems Handbook: Testing, adjusting, and balancing.
 - c. NEBB: Procedural standards for testing, balancing, and adjusting of environmental systems.

3. Submittals:
 - a. Submit name of adjusting and balancing agency for approval.
 - b. Submit draft copies of report for review prior to final acceptance of project. Provide final copies for Owner's personnel and for inclusion in operating and maintenance manuals.
 - c. Provide reports in soft cover, letter size, 3-ring binder manuals, complete with index page and indexing tabs, with cover identification at front and side. Include set of reduced Drawings with air outlets and equipment identified to correspond with data sheets and indicating thermostat locations.

4. Report forms:
 - a. Submit reports on AABC National Standards for Total System Balance or NEBB forms.
 - b. Forms shall include the following information:
 - 1) Title page:
 - a) Company name
 - b) Company address
 - c) Company telephone number
 - d) Project name
 - e) Project location
 - f) Project Foundation Representative
 - g) Project Foundation Representative
 - h) Project Contractor
 - i) Project altitude
 - 2) Instrument list:
 - a) Instrument
 - b) Manufacturer
 - c) Model
 - d) Serial number
 - e) Range
 - f) Calibration date
 - 3) Air moving equipment:
 - a) Location
 - b) Manufacturer
 - c) Model
 - d) Air flow, specified and actual
 - e) Return air flow, specified and actual
 - f) Outside air flow, specified and actual
 - g) Total static pressure (total external), specified and actual
 - h) Inlet pressure
 - i) Discharge pressure
 - j) Fan RPM
 - 4) Exhaust fan data:
 - a) Location
 - b) Manufacturer
 - c) Model
 - d) Air flow, specified and actual
 - e) Total static pressure (total external), specified and actual

- f) Inlet pressure
 - g) Discharge pressure
 - h) Fan RPM
- 5) Electric motors:
- a) Manufacturer
 - b) HP/BHP
 - c) Phase, voltage, amperage; nameplate, actual, no load.
 - d) RPM
 - e) Service factor
 - f) Starter size, rating, heater elements
- 6) Air inlets and outlets:
- a) Design supply, return, or exhaust air quantity
 - b) Actual supply, return, or exhaust air quantity
5. Air balance tolerances:
- a. Air balance shall be made with least possible friction.
 - b. Allowances shall be made for air filter resistance at the time of the tests. The main air supplies shall be at design air quantity with pressure drop across the air filter bank at simulated dirty condition. The room air supply shall be plus 10%, minus 0% from the design air quantity for rooms with an air supply of under 1000 cfm and plus or minus 5% where the air supply is 1000 cfm or more. In rooms with multiple supply outlets, the air supplied shall be within plus 5%, minus 0% of the design air quantity.
6. Project Record Documents:
- a. Submit record documents.
 - b. Accurately record actual locations of flow measuring stations and balancing valves and rough setting.
7. Quality Assurance:
- a. Agency shall be company specializing in the adjusting and balancing of systems specified with a minimum of 3 years experience. Perform work under supervision of AABC Certified Test and Balance Foundation Representative or NEBB Certified Testing, Balancing, and Adjusting Supervisor.
 - b. Total system balance shall be performed in accordance with AABC National Standards for Field Measurement and Instrumentation, Total System Balance, ASHRAE Systems Handbook, or NEBB Procedural Standards for Testing, Balancing, and Adjusting of Environmental Systems.
8. Schedule and sequence work to ensure completion of work before substantial completion of Project.
9. Agencies: The following agencies are acceptable for this Project:
- a. National Air Balance
 - b. Mechanical Environmental Systems (MESA)
 - c. Air Metrics
10. Examination:

- a. Before commencing work, verify that systems are complete and operable. Ensure the following:
 - 1) Equipment is operable and in a safe and normal condition.
 - 2) Temperature control systems are installed complete and operable.
 - 3) Proper thermal overload protection is in place for electrical equipment.
 - 4) Final filters are clean and in place. If required, install temporary media in addition to final filters.
 - 5) Duct systems are clean of debris.
 - 6) Correct fan rotation.
 - 7) Fire and volume dampers are in place and open.
 - 8) Coil fins have been cleaned and combed.
 - 9) Access doors are closed and duct end caps are in place.
 - 10) Air outlets are installed and connected.
 - 11) Duct system leakage has been minimized.
 - 12) Service and balance valves are open.
 - 13) Report any defects or deficiencies noted during performance of service to the Foundation Representative.
 - 14) Promptly report abnormal conditions in mechanical systems or conditions which prevent system balance.
 - 15) If, for design reasons, system cannot be properly balanced, report as soon as observed.
 - 16) Beginning of work means acceptance of existing conditions.

- 11. Preparation:
 - a. Provide instruments required for testing, adjusting, and balancing operations.
 - b. Provide additional balancing devices as required.

- 12. Adjusting:
 - a. Recorded data shall represent actually measured or observed condition.
 - b. Permanently mark settings of valves, dampers, and other adjustment devices allowing settings to be restored. Set and lock memory stops.
 - c. After adjustment, take measurements to verify balance has not been disrupted or that such disruption has been rectified.
 - d. Leave systems in proper working order, replacing belt guards, closing access doors, closing doors to electrical switch boxes, and restoring thermostats to specified settings.
 - e. At final inspection, recheck random selections of data recorded in report.

- 13. Air System Procedure:
 - a. Adjust air handling and distribution systems to provide required or design supply, return, and exhaust air quantities.
 - b. Make air quantity measurements in ducts by Pitot tube traverse of entire cross sectional area of duct.
 - c. Measure air quantities at air inlets and outlets.
 - d. Adjust distribution system to obtain uniform space temperatures free from objectionable drafts and noise.
 - e. Use volume control devices to regulate air quantities only to extent that adjustments do not create objectionable air motion or sound levels. Effect volume control by duct internal devices such as dampers and splitters.

- f. Vary total system air quantities by adjustment of fan speeds. Install drive changes as required. Contractor will be reimbursed for the cost of any drive changes required. Vary branch air quantities by damper regulation.
- g. Provide system schematic with required and actual air quantities recorded at each outlet or inlet.
- h. Measure static air pressure conditions on air supply units, including filter and coil pressure drops, and total pressure across the fan. Make allowances for 50 percent loading of filters.
- i. Adjust outside air automatic dampers, outside air, return air, and exhaust dampers for design conditions.
- j. Measure temperature conditions across outside air, return air, and exhaust dampers to check leakage.

PART 3 - INSTALLATION

3.01 GENERAL

- A. For the actual fabrication, installation, and testing of work under this Section, use only thoroughly trained and experienced workmen who are properly qualified for the work they perform. All installers are to be completely familiar with the manufacturer's current recommended methods of installation and shall so execute.

3.02 EQUIPMENT

- A. All equipment is to be installed to meet the manufacturer's installation instructions, guidelines, and recommendations.

3.03 DUCTWORK AND ACCESSORIES

- A. Installation:
 - 1. Locate ducts with sufficient space around equipment to allow normal operating and maintenance activities.
 - 2. Connect diffusers to low pressure ducts in concealed locations with 5 feet maximum length of flexible duct. Hold in place with strap or clamp to prevent duct from collapsing above diffuser.
 - 3. Provide balancing dampers at points on supply, return, and exhaust systems where branches are taken from larger ducts as required for air balancing.
 - 4. Provide fire dampers and fire/smoke dampers at locations indicated. Install with required perimeter mounting angles, sleeves, breakaway duct connection, corrosion resistant springs, bearings, bushings, and hinges. Follow the manufacturer's installation instructions.
 - 5. Provide flexible connections immediately adjacent to equipment in ducts associated with fans and motorized equipment.
 - 6. Provide duct access doors for inspection and cleaning before and after filters, coils, fans, automatic dampers, at fire dampers, and fire/smoke dampers and elsewhere as indicated. Provide minimum 8 x 8 inch size for hand access, 18 x 18 inch size for shoulder access, and as indicated.
 - 7. Provide duct test holes where indicated and required for testing and balancing purposes.
 - 8. Check location of outlets and inlets and make necessary adjustments in position to conform with Architectural features, symmetry, and lighting arrangement.
 - 9. Install diffusers to ductwork with airtight connection.
 - 10. Paint ductwork visible behind air outlets and inlets matte black.

3.04 MECHANICAL IDENTIFICATION

A. Installation:

1. Degrease and clean surfaces to receive adhesive for identification materials.
2. Plastic nameplates: Install with corrosive-resistant mechanical fasteners or adhesive.
3. Plastic or metal tags: Install with corrosive-resistant chain.
4. Plastic pipe markers: Install in accordance with manufacturer's instructions.
5. Equipment: Identify air handling units, pumps, heat transfer equipment, tanks, and water treatment devices with plastic nameplates. Small devices may be identified with plastic metal tags.
6. Controls: Identify control panels and major control components' outside panels with plastic nameplates.
7. Valves: Identify valves in main and branch piping with tags.
8. Piping: Identify piping, concealed or exposed, with plastic pipe markers. Tags may be used on small diameter piping. Identify service, flow direction, and pressure. Install in clear view and align with axis of piping. Location of identification not to exceed 20 feet on straight runs including risers and drops, adjacent to each valve and "T", at each side of penetration of structure or enclosure, and at each obstruction.
9. Ductwork: Identify ductwork with plastic nameplates or stenciled painting. Identify as to air handling unit number and area served. Locate identification at air handling unit, at each side of penetration of structure or enclosure, and at each obstruction.
10. Provide valve chart and schedule in aluminum frame with clear plastic shield. Install at location as directed.

3.05 SUPPORTS AND ANCHORS

A. Fabrication:

1. Size sleeves large enough to allow for movement due to expansion and contraction. Provide for continuous insulation wrapping.
2. Design hangers without disengagement of supported pipe.
3. Prime coat exposed steel hangers and supports. Hangers and supports located in crawl spaces, pipe shafts, and suspended ceiling spaces are not considered exposed.

B. Equipment bases and supports:

1. Provide templates, anchor bolts, and accessories for mounting and anchoring equipment.

C. Flashing:

1. Provide flexible flashing and metal counterflashing where piping and ductwork penetrate weather or waterproofed walls, floors, and roofs.
2. Provide acoustical lead flashing around ducts and pipes penetrating equipment rooms, installed in accordance with manufacturer's instructions for sound control.

D. Sleeves:

1. Extend sleeves through floors 1 inch above finished floor level. Caulk sleeves full depth and provide floor plate.

2. Where piping or ductwork penetrates floor, ceiling, or wall, close off space between pipe or duct and adjacent work with fire stopping insulation and caulk seal airtight. Provide close fitting metal collar or escutcheon covers at both sides of penetration. Firestopping to be installed per manufacturer's instructions.
3. Install steel escutcheons at finished surfaces.

3.06 SYSTEM TEST AND STARTUP

- A. Check the installation and connection requirements for conformance with the manufacturer's installation instructions for each piece of equipment. Perform the step-by-step checkout and startup procedures for each piece of equipment in accordance with the manufacturer's startup instructions.
- B. Coordinate the control requirements with the Electrical Contractor.
- C. The Mechanical Contractor is to coordinate the efforts of the Test and Balance Contractor and the Electrical Contractor to ensure that all systems are tested and performing as intended.
- D. Make all necessary control and system adjustments and operate the system in its final configuration for a period of ten (10) working days for the purpose of proving satisfactory performance. During this period, instruct such persons as Owner may designate in proper operation, care, and maintenance of the systems.

END OF SECTION



OFFICE OF FACILITIES MANAGEMENT

50 PHELAN AVENUE • BOX S142 • SAN FRANCISCO, CA 94112 • 415.452.5277 FAX 415.239.3480

Transmittal

To: Lyndon Chee
Ruiz & Sperow
2000 Powell Street, Suite 1655
Emeryville, CA 94608

Date: November 4, 2009

From: Marian Lam

Cc:

RE: Chinatown/North Beach Campus Bidding – Bid Protests

Urgent For Review Please Comment Please Reply Please Recycle

Notes/Comments:

Lyndon,

Enclosed is a binder of the documents related to the bid protests for our Chinatown/North Beach Campus project.

I have also included the "Instructions to Bidders" section from the specs.

Please contact me if you have any questions or need any additional information to complete your review.

Thank you,
Marian

BOARD OF TRUSTEES

MILTON MARKS III, PRESIDENT • DR. NATALIE BERG, VICE PRESIDENT
DR. ANITA GRIER • CHRIS JACKSON • STEVE NGO • JOHN RIZZO • LAWRENCE WONG, ESQ.
JOSHUA NIELSEN, STUDENT TRUSTEE • DR. DON Q. GRIFFIN, CHANCELLOR



OFFICE OF FACILITIES MANAGEMENT

50 PHELAN AVENUE • BOX S142 • SAN FRANCISCO, CA 94112 • 415.452.5277 FAX 415.239.3480

Transmittal

To: Lyndon Chee
Ruiz & Sperow
2000 Powell Street, Suite 1655
Emeryville, CA 94608

Date: November 4, 2009

From: Marian Lam

Cc:

RE: Chinatown/North Beach Campus Bidding – Bid Protests

Urgent For Review Please Comment Please Reply Please Recycle

Notes/Comments:

Lyndon,

Enclosed is a binder of the documents related to the bid protests for our Chinatown/North Beach Campus project.

I have also included the "Instructions to Bidders" section from the specs.

Please contact me if you have any questions or need any additional information to complete your review.

Thank you,
Marian

BOARD OF TRUSTEES

MILTON MARKS III, PRESIDENT • DR. NATALIE BERG, VICE PRESIDENT
DR. ANITA GRIER • CHRIS JACKSON • STEVE NGO • JOHN RIZZO • LAWRENCE WONG, ESQ.
JOSHUA NIELSEN, STUDENT TRUSTEE • DR. DON Q. GRIFFIN, CHANCELLOR

Room Usage Chart for Fall 2009 and Spring 2010: Alemany Campus, Cloud, Science, Statler Wing and Batmale Buildings

BLDG	Room	Days	Begin Time	End Time	Start Date	End Date
ALEM	102	M-T-W-TH-F	815	1014	16-Sep	17-Nov
ALEM	102	M-T-W-TH-F	815	1014	17-Aug	15-Sep
ALEM	102	M-T-W-TH-F	815	1014	17-Aug	15-Sep
ALEM	102	M-T-W-TH-F	1015	1214	10-Dec	18-Dec
ALEM	102	M-T-W-TH-F	1015	1214	18-Nov	30-Nov
ALEM	102	M-T-W-TH-F	1015	1214	17-Aug	16-Oct
ALEM	102	M-T-W-TH-F	1015	1214	19-Oct	17-Nov
ALEM	102	M-T-W-TH-F	1015	1214	1-Dec	9-Dec
ALEM	102	M-T-W-TH-F	1215	1314	17-Aug	18-Dec
ALEM	102	M-T-W-TH-F	1315	1514	19-Oct	18-Dec
ALEM	102	M-T-W-TH-F	1315	1514	17-Aug	16-Oct
ALEM	102	M-T-W-TH-F	1315	1514	19-Oct	18-Dec
ALEM	102	M-T-W-TH-F	1315	1514	17-Aug	16-Oct
ALEM	102	M-T-W-TH-F	1515	1714	17-Aug	16-Oct
ALEM	102	M-T-W-TH-F	1515	1714	17-Aug	16-Oct
ALEM	102	M-T-W-TH-F	815	1014	22-Feb	27-Apr
ALEM	102	M-T-W-TH-F	815	1014	19-Jan	19-Feb
ALEM	102	M-T-W-TH-F	1015	1214	19-Jan	19-Mar
ALEM	102	M-T-W-TH-F	1015	1214	22-Mar	27-Apr
ALEM	102	M-T-W-TH-F	1015	1214	28-Apr	27-May
ALEM	102	M-T-W-TH-F	1015	1214	10-May	18-May
ALEM	102	M-T-W-TH-F	1015	1214	19-May	27-May
ALEM	102	M-T-W-TH-F	1215	1314	19-Jan	27-May
ALEM	102	M-T-W-TH-F	1215	1314	19-Jan	27-May
ALEM	102	M-T-W-TH-F	1315	1514	19-Jan	19-Mar
ALEM	102	M-T-W-TH-F	1315	1514	22-Mar	27-May
ALEM	102	M-T-W-TH-F	1315	1514	19-Jan	19-Mar
ALEM	102	M-T-W-TH-F	1315	1514	22-Mar	27-May
ALEM	102	M-T-W-TH-F	1515	1614	19-Jan	27-May
ALEM	102	M-T-W-TH-F	1515	1614	19-Jan	27-May
ALEM	103	T-TH	1530	1929	15-Mar	22-Mar
ALEM	All Classes	M-T	1830	2059	17-Aug	20-Dec
ALEM	All Classes	M-T	1830	2059	19-Jan	27-May
ALEM	All Classes	M-T	1830	2059	19-Jan	27-May
ALEM	All Classes	M-T-W-TH	845	959	17-Aug	20-Dec
ALEM	All Classes	M-T-W-TH	1715	1829	17-Aug	20-Dec
ALEM	All Classes	M-T-W-TH	1715	1829	17-Aug	20-Dec
ALEM	All Classes	M-T-W-TH	1715	1829	17-Aug	20-Dec
ALEM	All Classes	M-T-W-TH	1715	1829	17-Aug	20-Dec
ALEM	All Classes	M-T-W-TH	1715	1829	17-Aug	20-Dec
ALEM	All Classes	M-T-W-TH	1715	1829	17-Aug	20-Dec





Room Usage Chart for Fall 2009 and Spring 2010: Alemany Campus, Cloud, Science, Statler Wing and Batmale Buildings

BLDG	Room	Days	Begin Time	End Time	Start Date	End Date
ALEM	All Classes	M-T-W-TH-F	1215	1314	19-Jan	27-May
ALEM	All Classes	M-T-W-TH-F	1215	1314	19-Jan	27-May
ALEM	All Classes	M-T-W-TH-F	1215	1314	19-Jan	27-May
ALEM	All Classes	M-T-W-TH-F	1315	1514	19-Jan	27-May
ALEM	All Classes	M-T-W-TH-F	1315	1514	19-Jan	27-May
ALEM	All Classes	M-T-W-TH-F	1315	1514	19-Jan	27-May
ALEM	All Classes	M-T-W-TH-F	1515	1714	19-Jan	27-May
ALEM	All Classes	M-T-W-TH-F	1515	1714	19-Jan	27-May
ALEM	All Classes	M-T-W-TH-F	1515	1714	19-Jan	27-May
ALEM	All Classes	M-T-W-TH-F	1515	1714	19-Jan	27-May

Room Usage Chart for Fall 2009 and Spring 2010: Alemany Campus, Cloud, Science, Statter Wing and Batmale Buildings

BLDG	Room	Days	Begin Time	End Time	Start Date	End Date
ALEM	All Classes	M-T-W-TH-Sat	815	1014	17-Aug	20-Dec

MECHANICAL LEGEND AND ABBREVIATIONS

SYMBOL	ABBREVIATION	DESCRIPTION	ABBREVIATION	DESCRIPTION
		BYPASS TIMER SWITCH - MOUNT AT +48" AFF	∅	DIAMETER
		EQUIPMENT TAG	∅	PHASE
	10"x10"-ES	EXHAUST GRILLE - TITUS MODEL 350ZRL. ALL STEEL. BAR GRILLE WITH 3/4" BLADE SPACING AND 0° FIXED DEFLECTION. PROVIDE 6" DEEP "B" BOX WITH NECK SIZE AS SHOWN. FOR GYPSUM BOARD CEILINGS. COLOR: OFF-WHITE.	CFM	CUBIC FEET PER MINUTE
	FD/SD	COMBINATION FIRE / SMOKE DAMPER		

MECHANICAL LIST OF DRAWINGS

MO.1	MECHANICAL LEGEND
MO.2	MECHANICAL SCHEDULE
M2.2	MECHANICAL SECOND FLOOR PLAN
MS.1	MECHANICAL DETAILS
MS.2	MECHANICAL CONTROL DIAGRAMS



MCCRACKEN & WOODMAN
Incorporated

TEL 510-783-4881 355 Grand Ave. Oakland, CA 94610
FAX 510-783-0619 www.mccracken-woodman.com

CCSF Alemany Campus
Phase II Accessibility Upgrade

MO.1

SCALE: AS NOTED 11/03/2009

PLUM | architects

212 Sutter St, 4th floor, San Francisco CA 94108
TEL: 415-837-0900 FAX: 415-837-0990

ROOF-MOUNTED CENTRIFUGAL EXHAUST FAN SCHEDULE

SYMBOL	MANUFACTURER	MODEL NO.	AIR QUANTITY (CFM)	STATIC PRESSURE (IN. W.G.)	VOLTAGE/ PHASE	HP	RPM	SONES	APPROX. OPER. WEIGHT (LBS)	NOTES
	GREENECK	G-080-D	200	0.38	120V/1φ	1/20	1550	7.3	40	①②③

EXHAUST FAN NOTES:

1. PROVIDE THE FOLLOWING:
 - A. ROOF CURB
 - B. BACKDRAFT DAMPER
 - C. BIRDSCREEN
 - D. DISCONNECT SWITCH
2. SPEED CONTROLLER MOUNTED UNDER FAN HOOD.
3. ADJUST FAN SPEED TO DELIVER REQUIRED CFM AT LOWEST POSSIBLE SPEED SETTING.



MCCRACKEN & WOODMAN
Incorporated

TR 510-763-4891 355 Grand Ave, Oakland, CA 94610
FAX 510-763-4619 www.mccracken-woodman.com

CCSF Alemany Campus
Phase II Accessibility Upgrade

M0.2

PLUM | architects
212 Sutter St, 4th floor, San Francisco CA 94108
TEL: 415-837-0900 FAX: 415-837-0990

SCALE: AS NOTED 11/03/2009

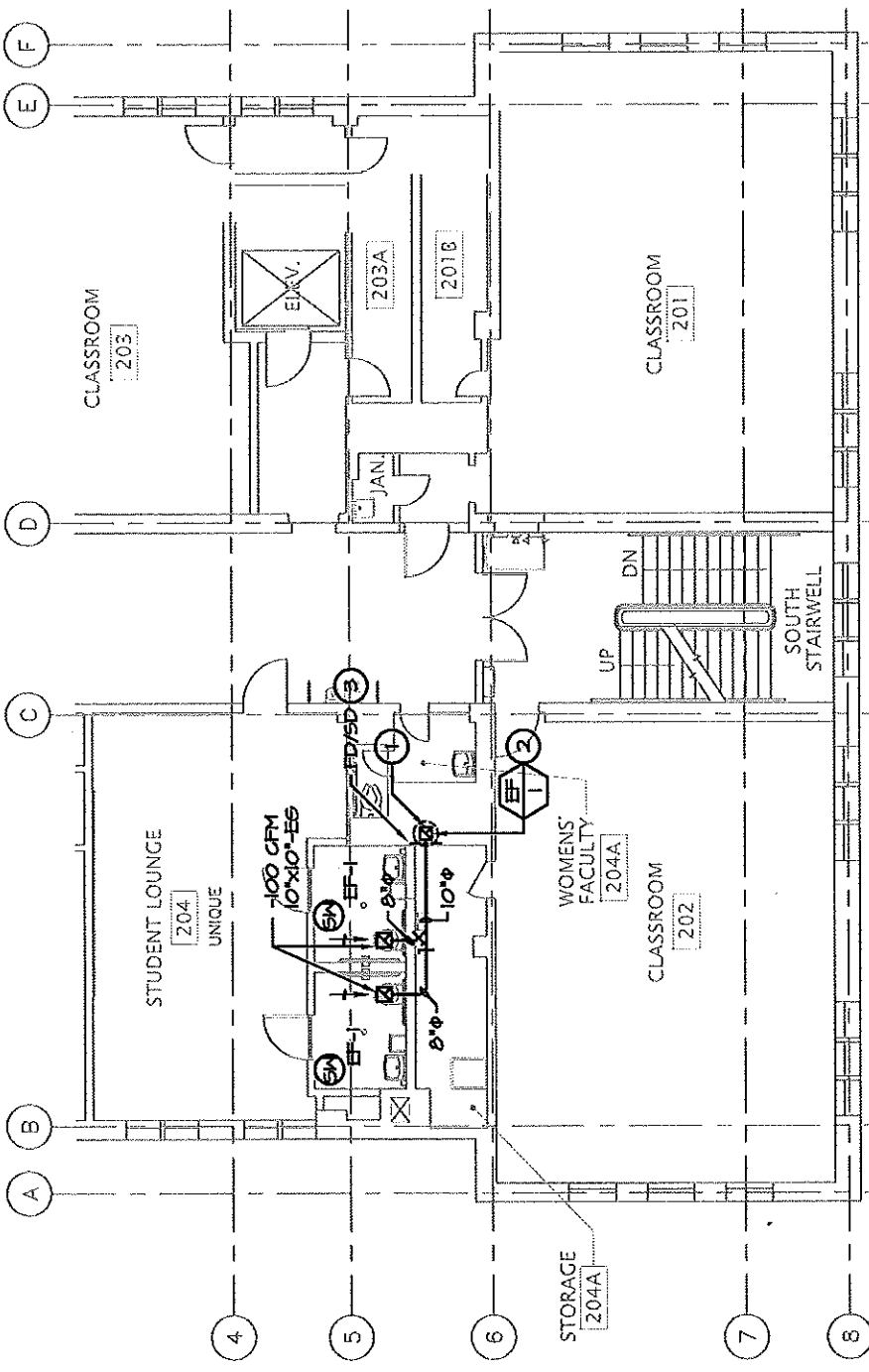

SHEET NOTES

1. RUN 10" ϕ EXHAUST DUCT UP IN EXISTING SHAFT. DUCT WILL NEED TO BE ROUTED AROUND EXISTING DUCT AND PIPE IN SHAFT. 10" ϕ EXHAUST IS TO RUN UP THROUGH THE THIRD FLOOR AND IS TO TRANSITION TO 10"X10" AND CONNECT TO EF-1 ROOF CURB.
2. EXHAUST FAN ON ROOF. EXHAUST FAN IS TO BE LOCATED A MINIMUM OF 10'-0" FROM ANY OUTSIDE AIR INTAKES OR OPENINGS INTO THE BUILDING. FOR EXHAUST FAN MOUNTING SEE DETAIL I/M3.1. FOR EXHAUST FAN CONTROL SEE DETAIL 2/M3.1.
3. FIRE/SMOKE DAMPER MOUNTED AT 10" ϕ EXHAUST DUCT PENETRATION OF EXISTING SHAFT, SEE DETAIL I/M3.2.

MECHANICAL SECOND FLOOR PLAN
 SCALE: 1/8" = 1'-0"

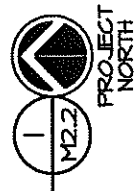

MCCRACKEN & WOODMAN
 incorporated
 TEL: 510-763-4851 355 Grand Ave, Oakland, CA 94616
 FAX: 510-763-0619 www.mcracken-woodman.com

CCSF Alemany Campus
Phase II Accessibility Upgrade
 SCALE: AS NOTED 11/03/2009

M2.2

PLUM | architects
 212 Sutter St, 4th floor, San Francisco CA 94108
 TEL: 415-837-0900 FAX: 415-837-0990

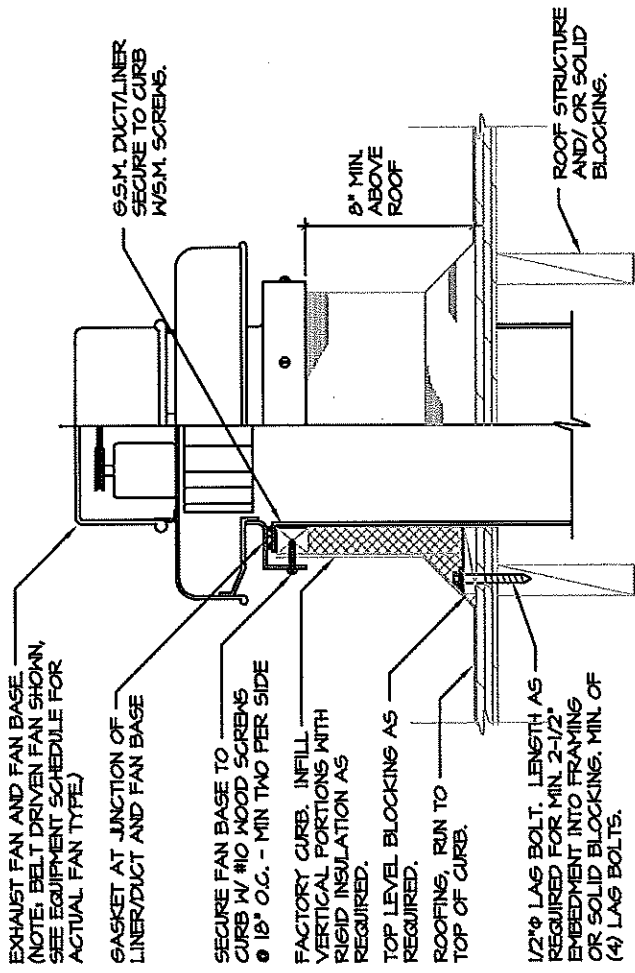

1
M3.1

ROOF MOUNTED EXHAUST FAN DETAIL

NO SCALE

MCCRACKEN & WOODMAN
Incorporated
TEL 510-783-4891 355 Grand Ave, Oakland, CA 94610
FAX 510-783-6619 www.mccracken-woodman.com

CCSF Alemany Campus
Phase II Accessibility Upgrade
SCALE: AS NOTED 11/03/2009

M3.1

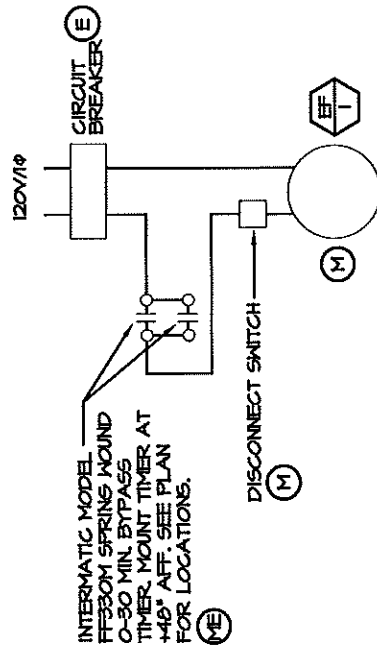

2
M3.1

EXHAUST FAN
SCHEMATIC CONTROL DIAGRAM

NO SCALE

PLUM | architects
212 Sutter St, 4th floor, San Francisco CA 94108
TEL: 415-837-0900 FAX: 415-837-0990

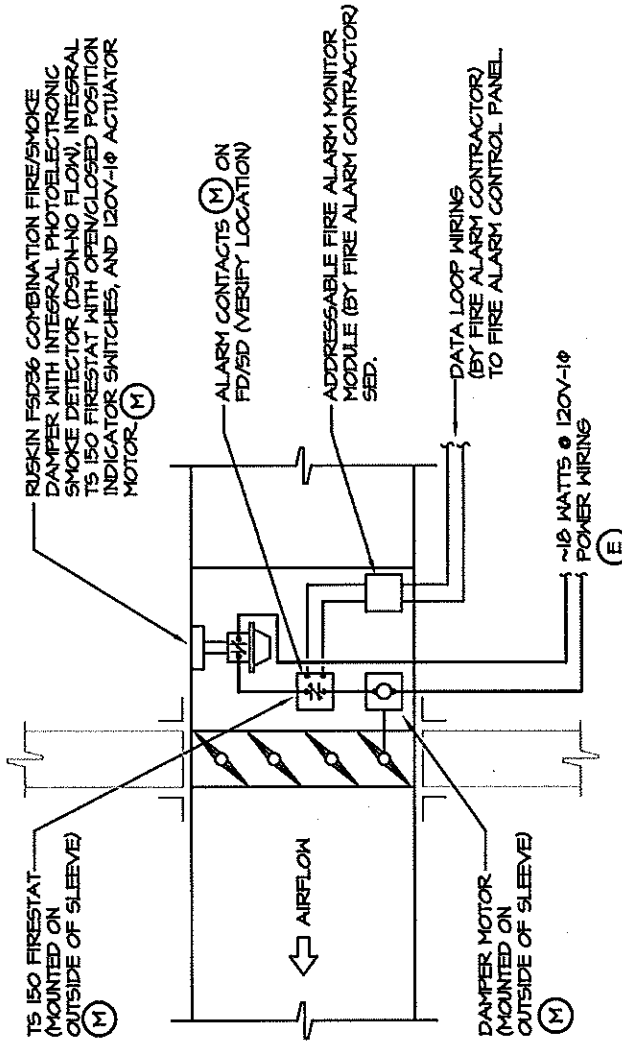

FIRE/SMOKE DAMPER CONTROL DIAGRAM

NO SCALE

NOTES:

1. FOR LOCATIONS ADJACENT TO WALL GRILLES USE RUSKIN FSD36FA FRONT ACCESS COMBINATION FIRE/SMOKE DAMPER WITH INTEGRAL PHOTOELECTRONIC SMOKE DETECTOR (DSDN-NO FLOW), INTEGRAL TS 150 FIRESTAT WITH OPEN/CLOSED POSITION INDICATOR SWITCHES, AND 120V-1Ø ACTUATOR MOTOR.
2. FOR ROUND DUCT LOCATIONS USE RUSKIN FSD60-2, SAME OPTIONS AS LISTED IN NOTE 1 ABOVE.
3. COMBINATION FIRE/SMOKE DAMPER TO BE FURNISHED AND INSTALLED BY MECHANICAL CONTRACTOR. SEE DIV. 28 - FIRE AND LIFE SAFETY FOR ALL WIRING.
4. INSTALL PER MANUFACTURER'S INSTALLATION INSTRUCTIONS.
5. INCREASE FIRE/SMOKE DAMPER SIZE IF REQUIRED TO ACCOMMODATE DUCT SMOKE DETECTOR SIZE. TRANSITION DUCTWORK TO DAMPER SIZE WITH SMOOTH TRANSITION FITTINGS AS REQUIRED. SMOKE DETECTOR MAY ALSO BE LOCATED UPSTREAM OF DAMPER IF IN ACCORDANCE WITH MANUFACTURER'S INSTALLATION INSTRUCTIONS.
6. INSTALL DUCT AND CEILING ACCESS DOORS AS REQUIRED FOR ACCESS TO ALL COMPONENTS INSIDE AND OUTSIDE DUCT.
7. VERIFY THAT ALL COMPONENTS ARE COMPATIBLE WITH FIRE ALARM SYSTEM.

1
M3.2

MCCracken & WOODMAN
Incorporated
TEL: 510-763-4891 355 Grand Ave. Oakland, CA 94610
FAX: 510-763-0678 www.mccracken-woodman.com

CCSF Alemany Campus
Phase II Accessibility Upgrade
SCALE: AS NOTED 11/03/2009

M3.2

PLUM | architects
212 Sutter St, 4th floor, San Francisco CA 94108
TEL: 415-837-0900 FAX: 415-837-0990

PLUMBING LEGEND AND ABBREVIATIONS

SYMBOL	ABBREVIATION	DESCRIPTION
(4)		SHEET NOTE DESIGNATION
(M)		ITEM FURNISHED AND INSTALLED BY MECHANICAL CONTRACTOR
(E)		ITEM FURNISHED AND INSTALLED BY ELECTRICAL CONTRACTOR
(P)		ITEM FURNISHED AND INSTALLED BY PLUMBING CONTRACTOR
(1/P2.1)		DETAIL REFERENCE - UPPER NUMBER=DETAIL NUMBER, LOWER NUMBER=SHEET NUMBER
---	S, SS, M	SANITARY SOIL OR WASTE PIPING
---	V	SANITARY VENT PIPING
---	CM	COLD WATER PIPING
---	(E)S, (E)SS	EXISTING SANITARY, SOIL OR WASTE PIPING TO REMAIN
---	(E)V	EXISTING SANITARY VENT PIPING TO REMAIN
---	(E)CW	EXISTING COLD WATER PIPING TO REMAIN

ABBREVIATION	DESCRIPTION
BF	BELOW FLOOR
CTE	CONNECT TO EXISTING
(E)	EXISTING
IFC	IN FURRED CEILING

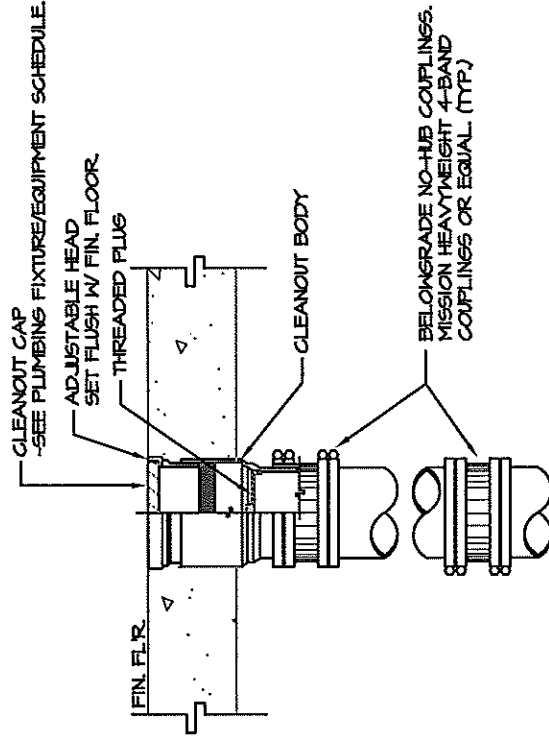

FLUSH FLOOR CLEANOUT DETAIL
NO SCALE

PLUMBING LIST OF DRAWINGS

PO.1	PLUMBING LEGEND AND DETAIL
PO.2	PLUMBING SCHEDULE
P1.1	PLUMBING FIRST FLOOR PLAN
P2.2	PLUMBING FIRST FLOOR PLAN

MCCRACKEN & WOODMAN
 Incorporated
 Tel: 510-763-4881 355 Grand Ave, Oakland, CA 94610
 Fax: 510-763-0619 www.mccracken-woodman.com

CCSF Alemany Campus
Phase II Accessibility Upgrade
 SCALE: AS NOTED 11/03/2009

PO.1

PLUM | architects
 212 Sutter St, 4th floor, San Francisco CA 94108
 TEL: 415-837-0900 FAX: 415-837-0990

PLUMBING FIXTURE/EQUIPMENT SCHEDULE

ITEM	DESCRIPTION	S OR W	V	CM	HW	SPECIFICATIONS AND REMARKS
WC	WATER CLOSET (ACCESSIBLE)	4"	2"	1"	-	ZURN Z5655 ULTRA LOW CONSUMPTION WATER CLOSET, FLOOR MOUNTED, ADA HEIGHT, ELONGATED, TOP SPUD. ZURN ZT56200EY, 128 GPF, SENSOR OPERATED, BATTERY POWERED FLUSH VALVE. ZURN Z545556-EL OPEN FRONT WHITE SEAT WITH STAINLESS STEEL HINGES, ZURN Z54T2-COMB CLOSET BOLT/MAX RING KIT.
LAV	LAVATORY (ACCESSIBLE)	2"	1-1/2"	1/2"	-	KOHLER K-2032 20-3/4x18-1/4 "GREENWICH" WITH 4" CENTERS AND CONCEALED ARMS. CHICAGO 857-665PSH PUSH BUTTON METERING FAUCET, E2B05-5JKCP 5 GPM OUTLET. ADJUST FOR 10 SEC RUN TIME. JAMECO 623203C CHROME PLATED GRID DRAIN WITH IT GA TAILPIECE. BRASSCRAFT H5CR19C HEAVY DUTY LOOSE KEY ANGLE STOP. DELIVER KEY TO OWNER. ZURN FLOOR MOUNTED CARRIER WITH CONCEALED ARMS. MOUNT AT ACCESSIBLE HEIGHT. INSTALL CLEANOUT TEE AND WCO IN WASTE RISER BELOW FIXTURE.
FCO	FLOOR CLEANOUT	LINE SIZE 4" MAX.	-	-	-	ZURN ZN-1400-BP-KC NICKEL BRONZE CLEANOUT WITH BRONZE PLUG, ANCHOR FLANGE AND CLAMPING COLLAR TO SECURE BUILDING WATERPROOF MEMBRANE AT TILED AREAS PROVIDE ZN-1400-BP-KC-T, SAME AS ABOVE EXCEPT WITH SQUARE TOP. SEE PLUMBING DETAILS FOR REQUIREMENTS.
WCO	WALL CLEANOUT	LINE SIZE 4" MAX.	-	-	-	ZURN Z-1446. SEE PLUMBING DETAILS FOR REQUIREMENTS.

PL 109040494372.dwg, 13/3/2009 4:21:52 PM



MCCRACKEN & WOODMAN
Incorporated
TEL 510-763-4851 355 Grand Ave, Oakland, CA 94610
FAX 510-763-0819 www.mccracken-woodman.com

CCSF Alemany Campus
Phase II Accessibility Upgrade

P0.2

PLUM | architects
212 Sutter St, 4th floor, San Francisco CA 94108
TEL: 415-837-0900 FAX: 415-837-0990

SCALE: AS NOTED 11/03/2009

SHEET NOTES

1. CONNECT NEW 1-1/2"CM TO EXISTING 2-1/2"CM EXPOSED IN CORRIDOR.
2. 1-1/2"CM UP IN WALL ABOVE. FOR CONTINUATION SEE DRAWING P2.2.

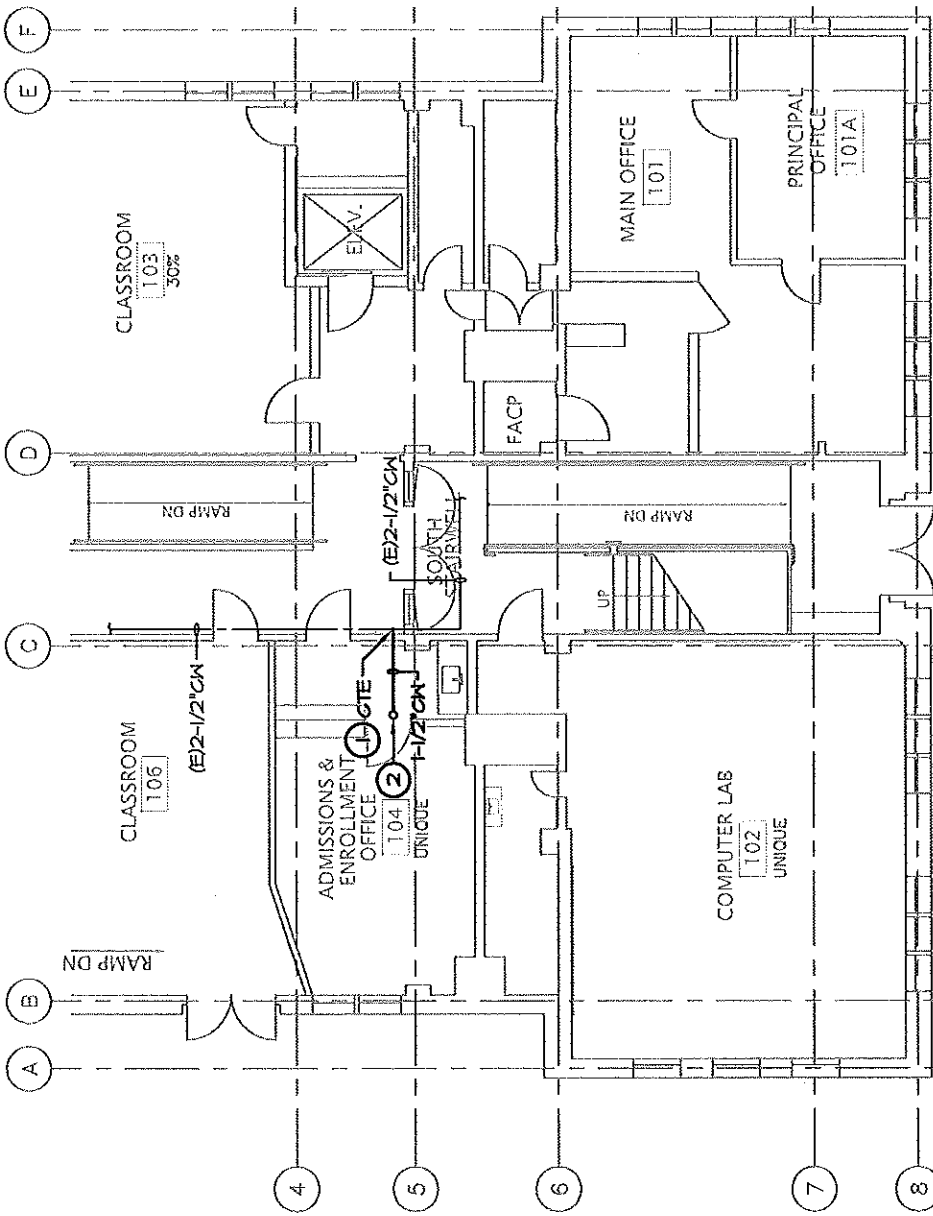

PLUMBING FIRST FLOOR PLAN
SCALE: 1/8" = 1'-0"



MCCRACKEN & WOODMAN
Incorporated
TEL 510-763-4491 355 Grand Ave, Oakland, CA 94610
FAX 510-763-0619 www.mccracken-woodman.com

CCSF Alemany Campus
Phase II Accessibility Upgrade
SCALE: AS NOTED 11/03/2009

P2.1

PLUM | architects
212 Sutter St, 4th floor, San Francisco CA 94108
TEL: 415-837-0900 FAX: 415-837-0990

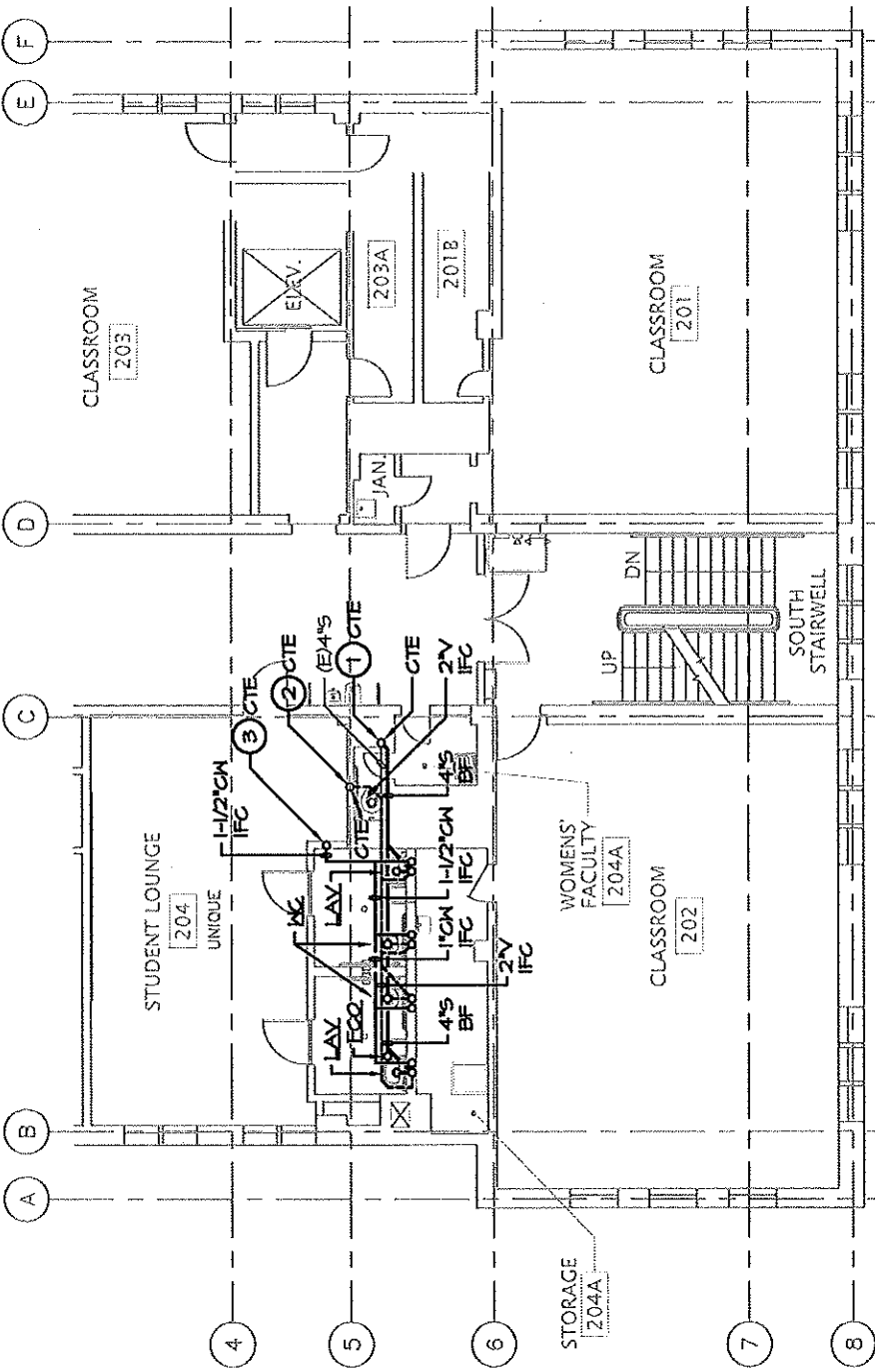

SHEET NOTES

1. CONNECT NEW 4" TO EXISTING 4" RISER. FIELD VERIFY ACTUAL LOCATION OF EXISTING 4" RISER.
2. CONNECT NEW 2" TO EXISTING 2" RISER. FIELD VERIFY ACTUAL LOCATION OF EXISTING 2" RISER.
3. RUN 1-1/2" DOWN IN MALL. FOR CONTINUATION SEE DRAWING P2.1.

PLUMBING SECOND FLOOR PLAN
SCALE: 1/8" = 1'-0"



MCCRACKEN & WOODMAN
Incorporated
TEL: 510-763-4891 355 Grand Ave, Oakland, CA 94610
FAX: 510-763-0619 www.mccracken-woodman.com

CCSF Alemany Campus
Phase II Accessibility Upgrade

P2.2

PLUM | architects
212 Sutter St, 4th floor, San Francisco CA 94108
TEL: 415-837-0900 FAX: 415-837-0990

SCALE: AS NOTED 11/03/2009